

GUDSMITH D3

ASSEMBLY INSTRUCTION

Thanks for purchasing one of our products, please read carefully the assembly instructions before installation (Attention: Do not tighten the screws before all screws are in place).



TWO PEOPLE REQUIRED

General Care:

- Keep your furniture out on direct sunlight-Use desk pads and coasters to protect the surface from dents, scatches and moisture from hot and cold liquids.

Cleaning:





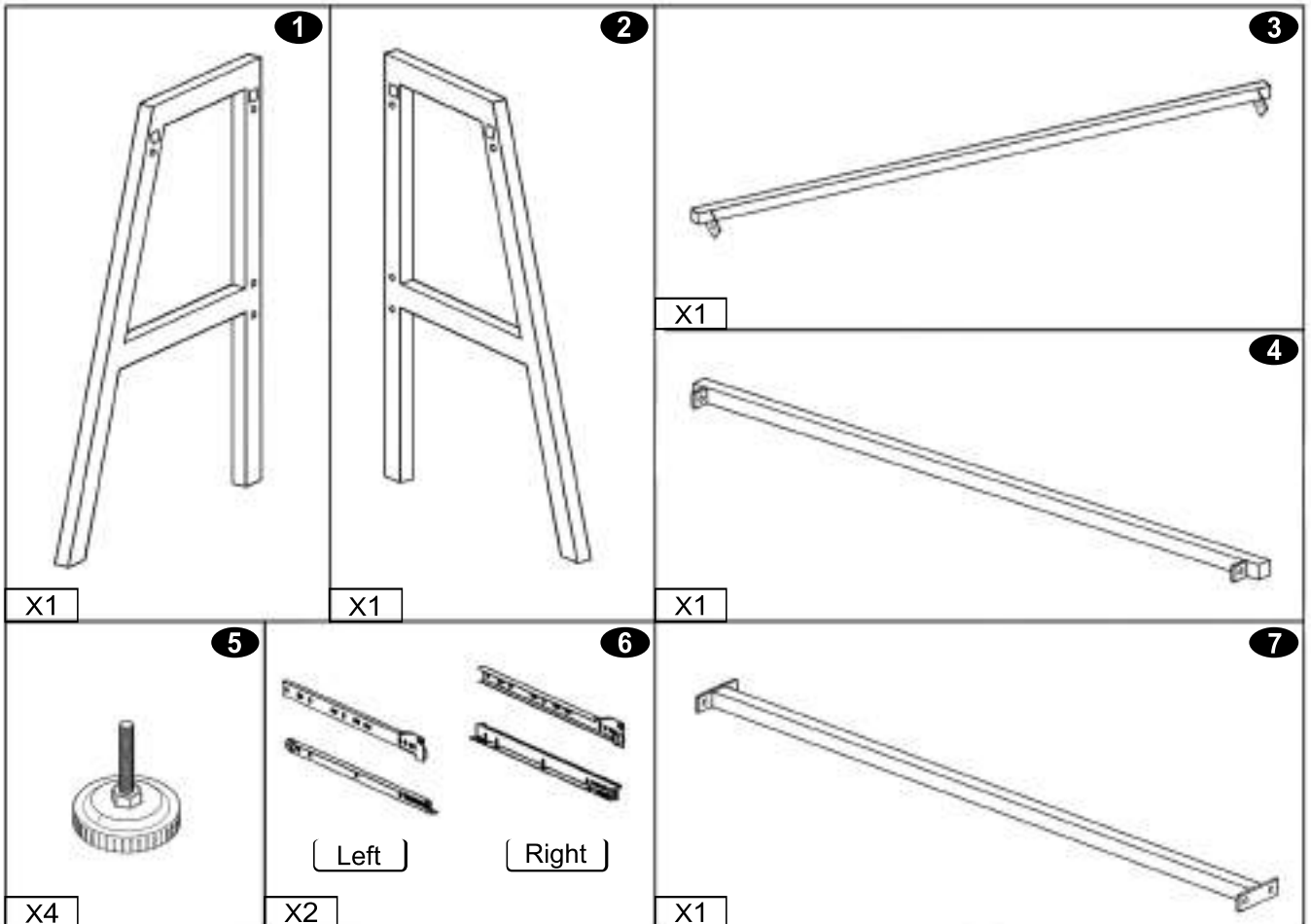
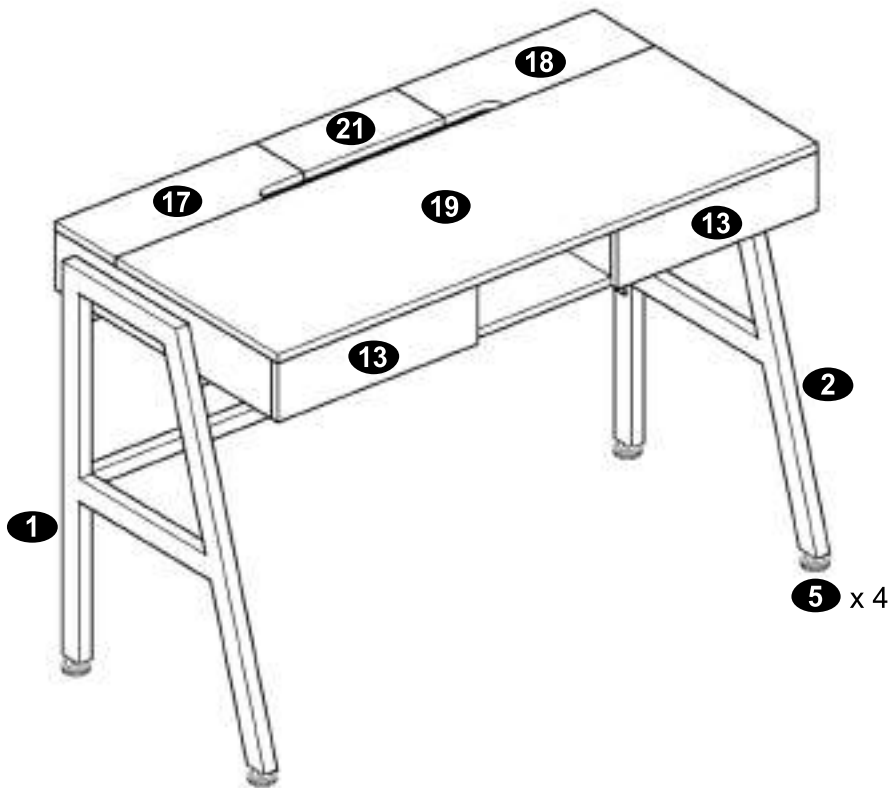

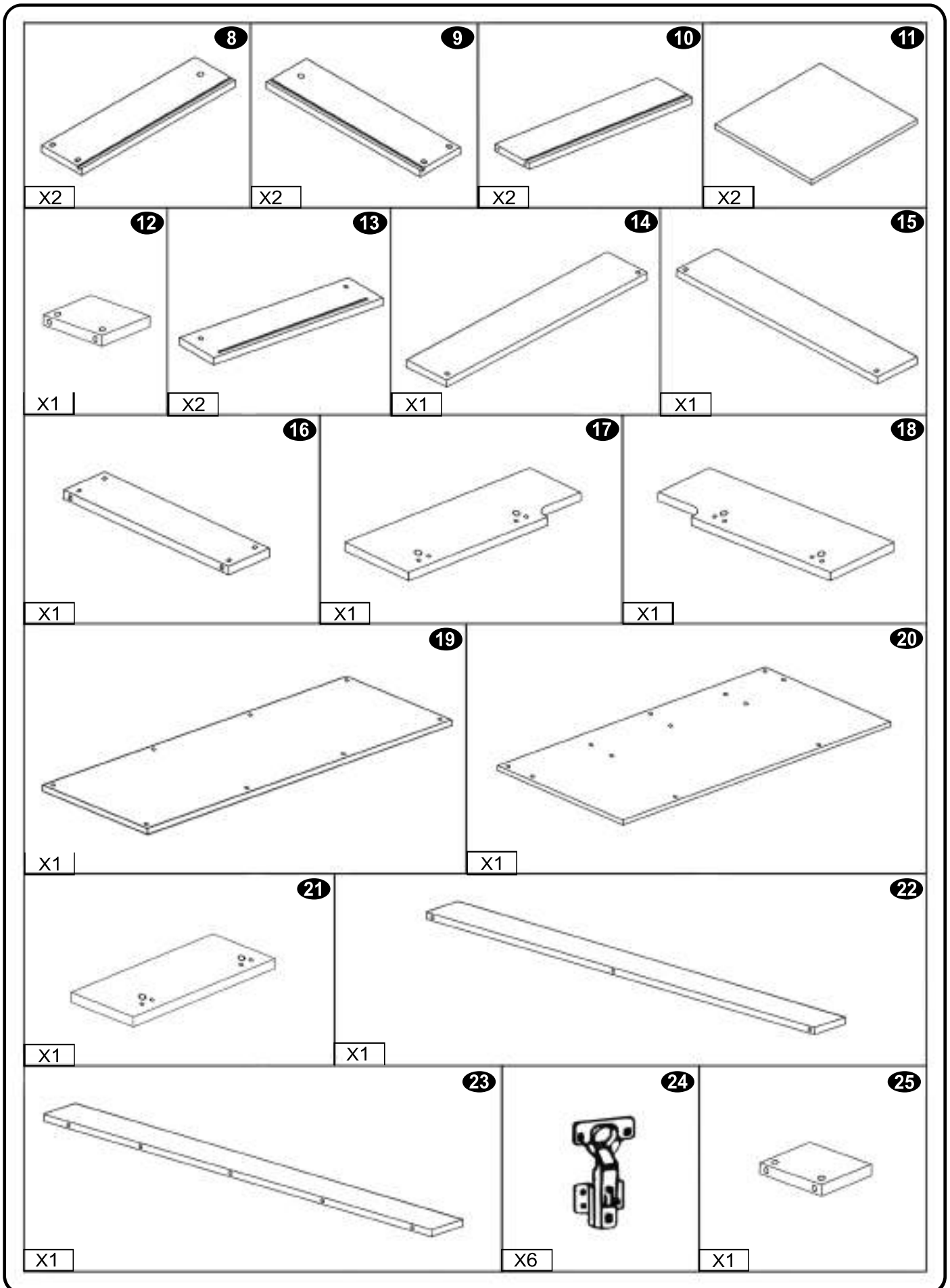
- For cleaning, wipe the surface with a damp (not with) cloth or wipe dry with a clean lint free cotton cloth.
- Window cleaning liquid or a similar cleaning liquid can be used to clean glass surfaces

• PARTS LIST

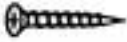

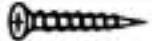
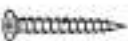

• SCREWS LIST

PART	QTY.	ITEM		PART	QTY.	ITEM	
A	24	5 x 13 MM		F	4	6 x 35 MM	
B	37	6 x 40 MM		G	37	Ø 15 MM	
C	24	8 x 40 MM		H	24	6 x 16 MM	
D	8	6 x 32 MM					
E	8	6 x 16 MM				M 4	

6x40 MM BOLTS INSTALLATION AS BELOW

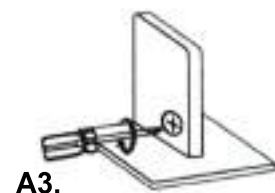
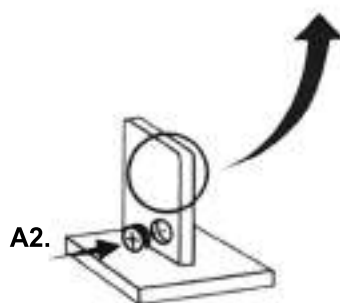
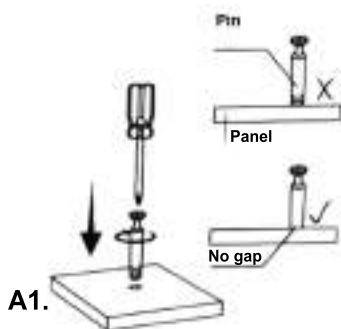
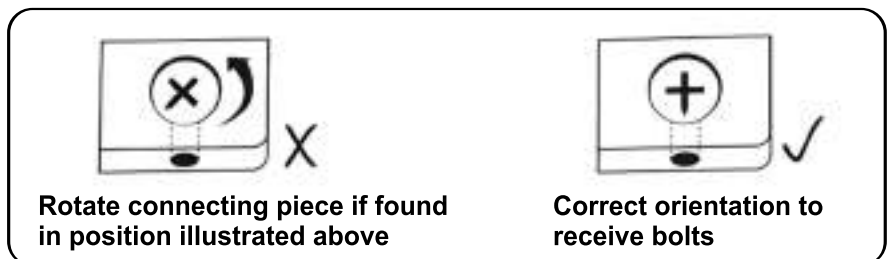
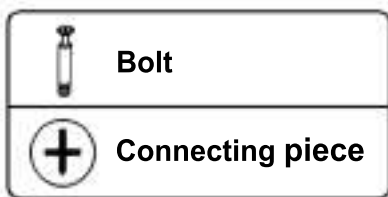

1

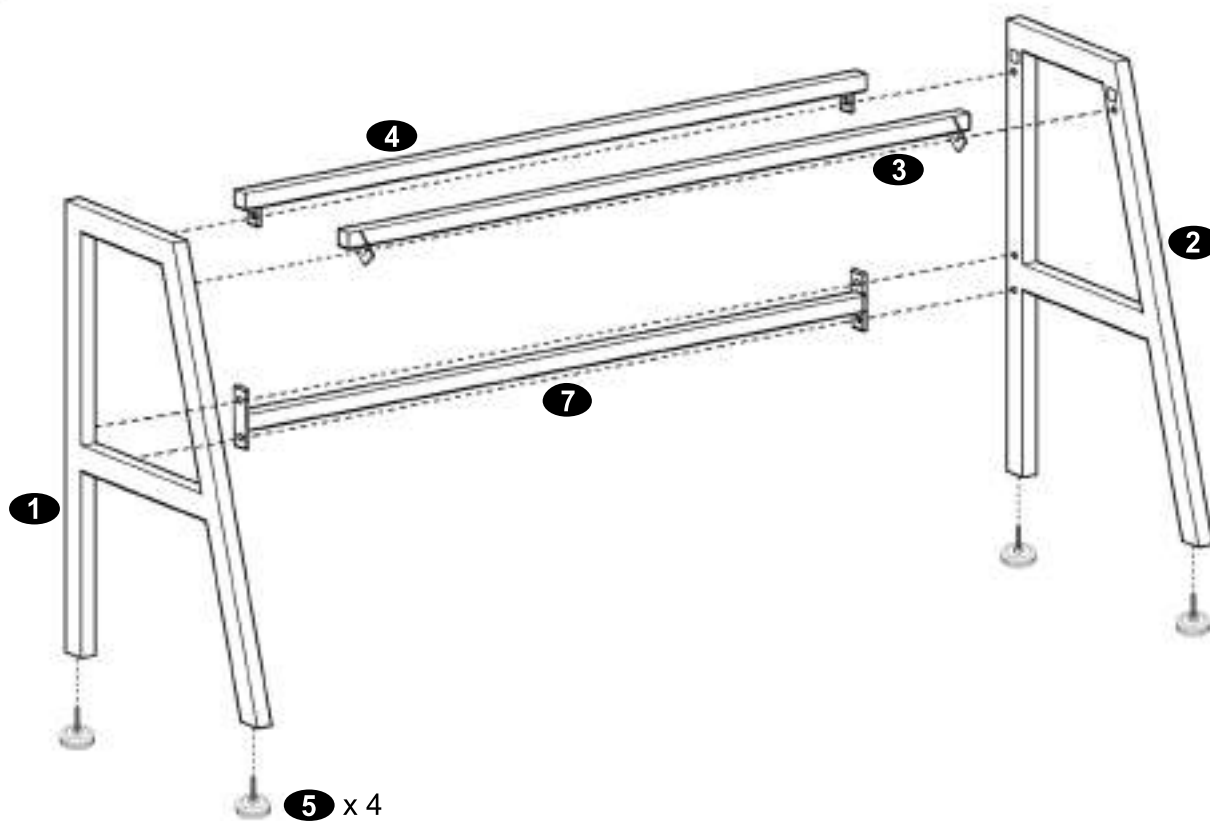

2

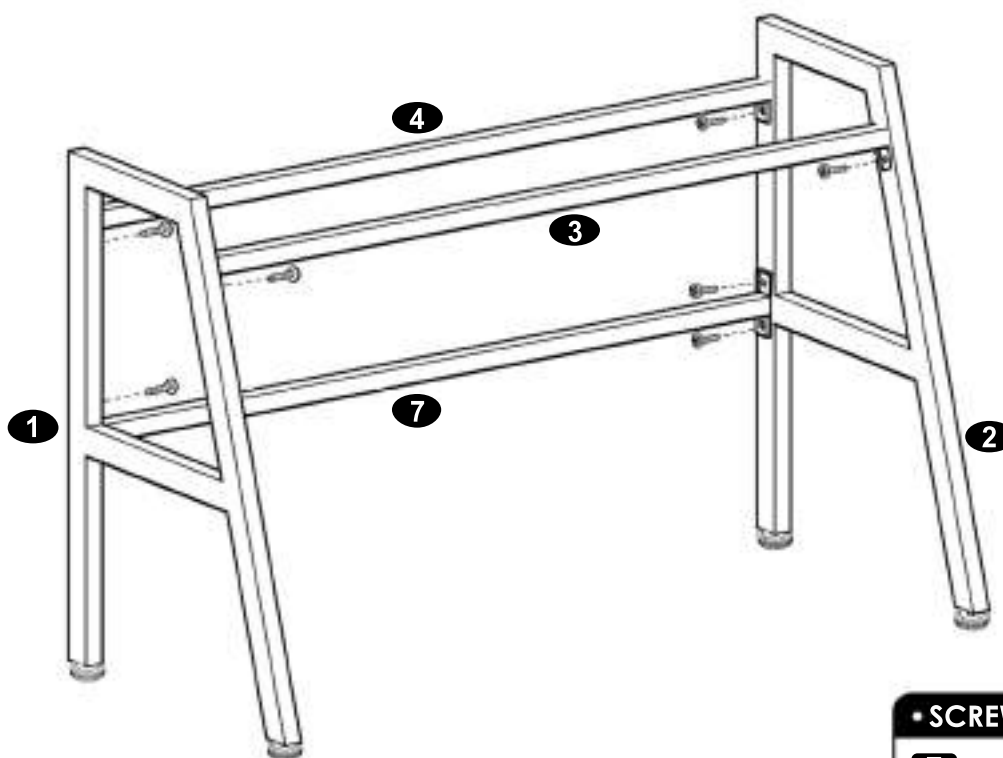

• SCREWS

E 6 x 16 MM

 x 8

 M4

3

• SCREWS

D 6 x 32 MM x 4

4

5

• SCREWS

B 6 x 40 MM x 2

G Ø 15 MM x 2

6



Repeat steps 3 to 6 to install the other drawers

• SCREWS

A 5 x 13 MM x 4

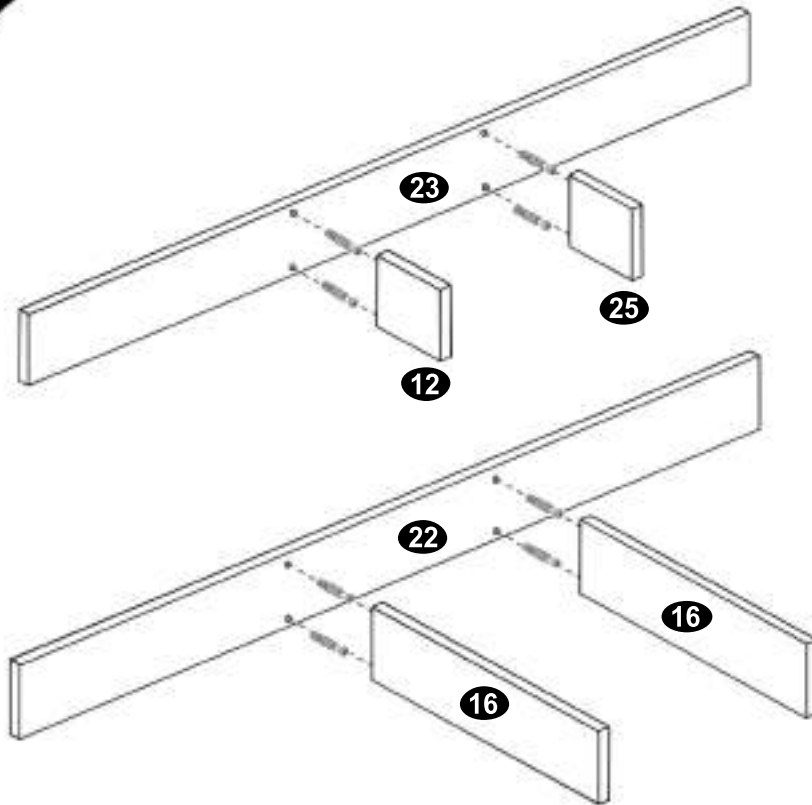

7



• SCREWS		
B	6 x 40 MM	
	x 8	
G	Ø 15 MM	
	x 8	

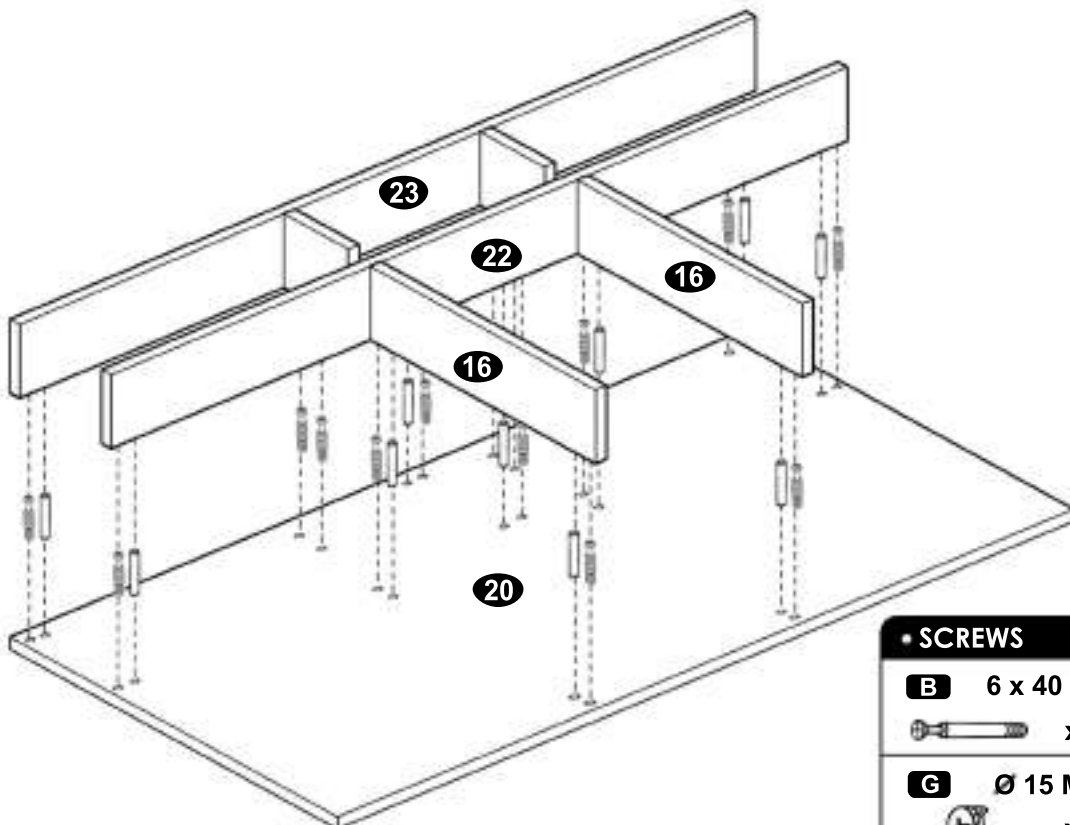

8

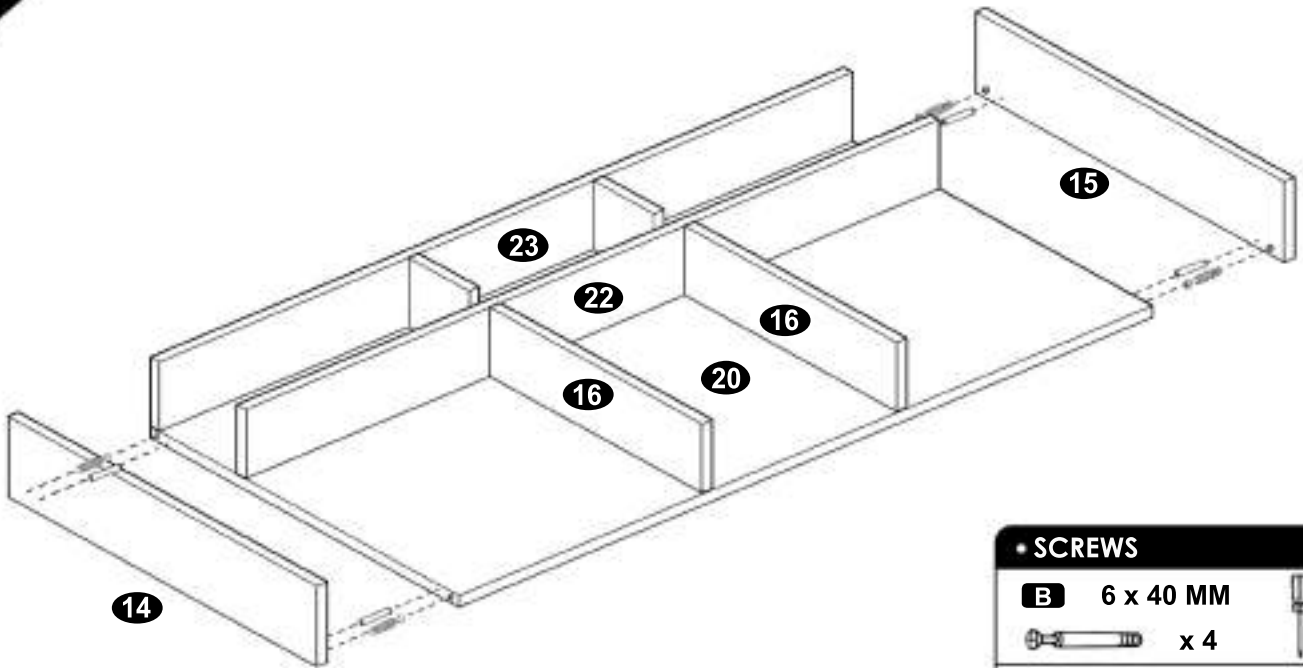

• SCREWS		
B	6 x 40 MM	
	x 13	
G	Ø 15 MM	
	x 13	
C	8 x 40 MM	
	x 10	

9



• SCREWS		
B	6 x 40 MM	
	x 4	
G	Ø 15 MM	
	x 4	
C	8 x 40 MM	
	x 4	



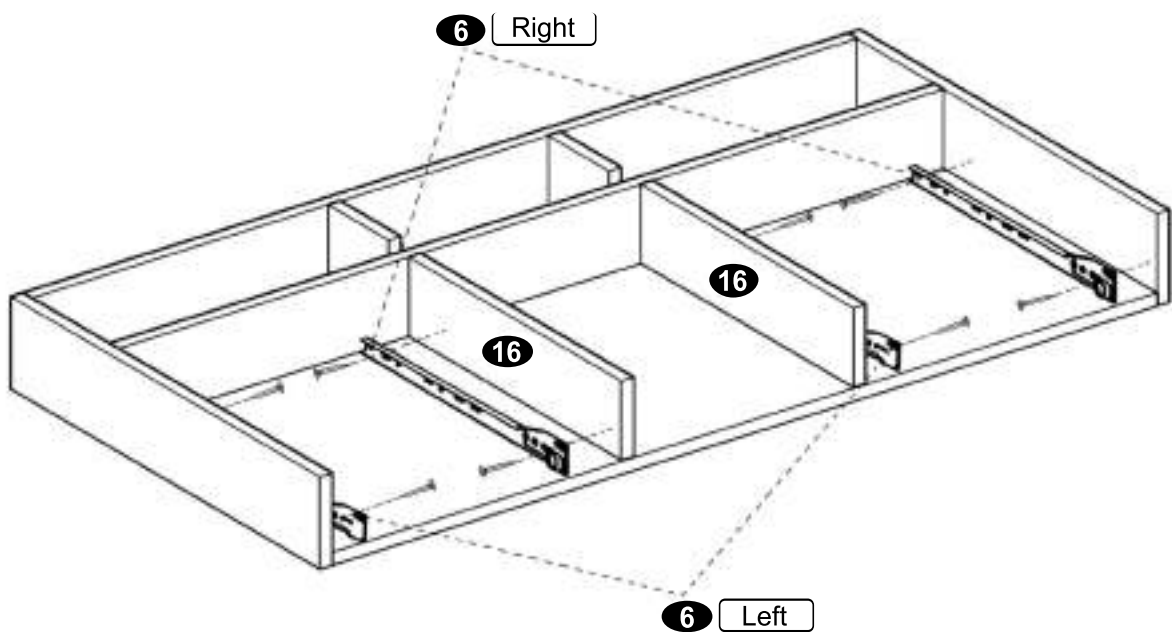



10

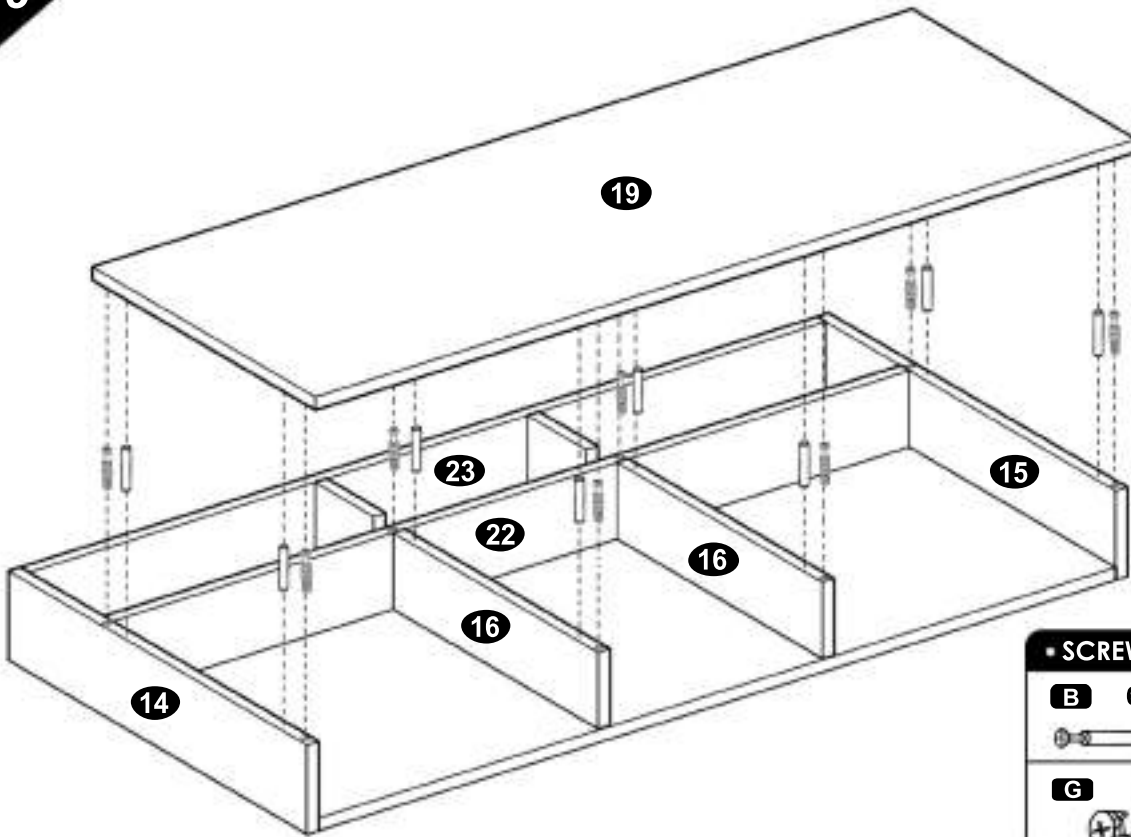

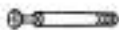
• SCREWS		
A	5 x 13 MM	
	x 8	



9

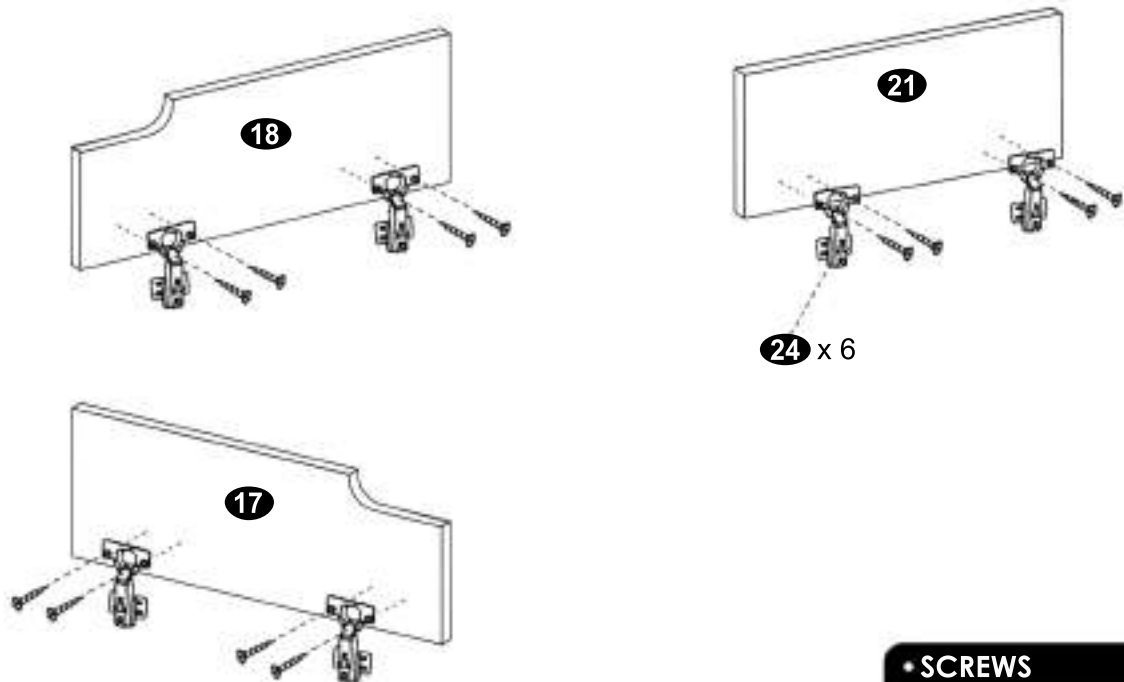

• SCREWS		
B	6 x 40 MM	
	x 8	
G	Ø 15 MM	
	x 8	
C	8 x 40 MM	
	x 8	

10

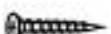

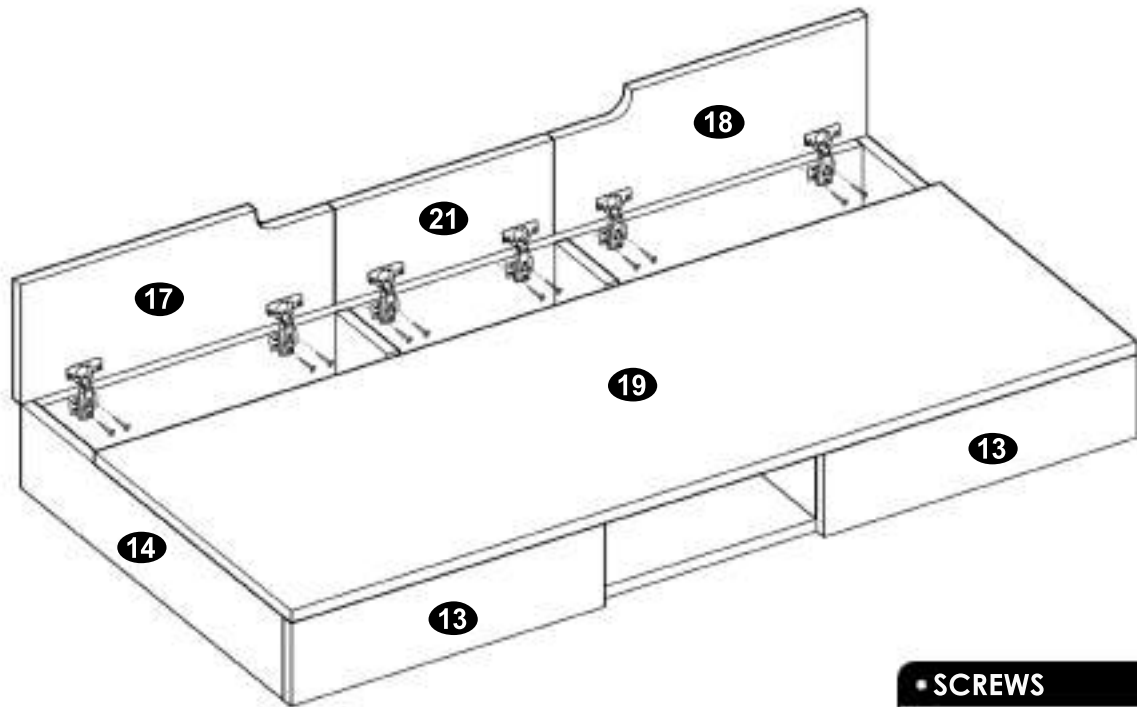

• SCREWS		
H	6 x 16 MM	
	x 12	

11

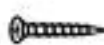

• SCREWS

H 6 x 16 MM

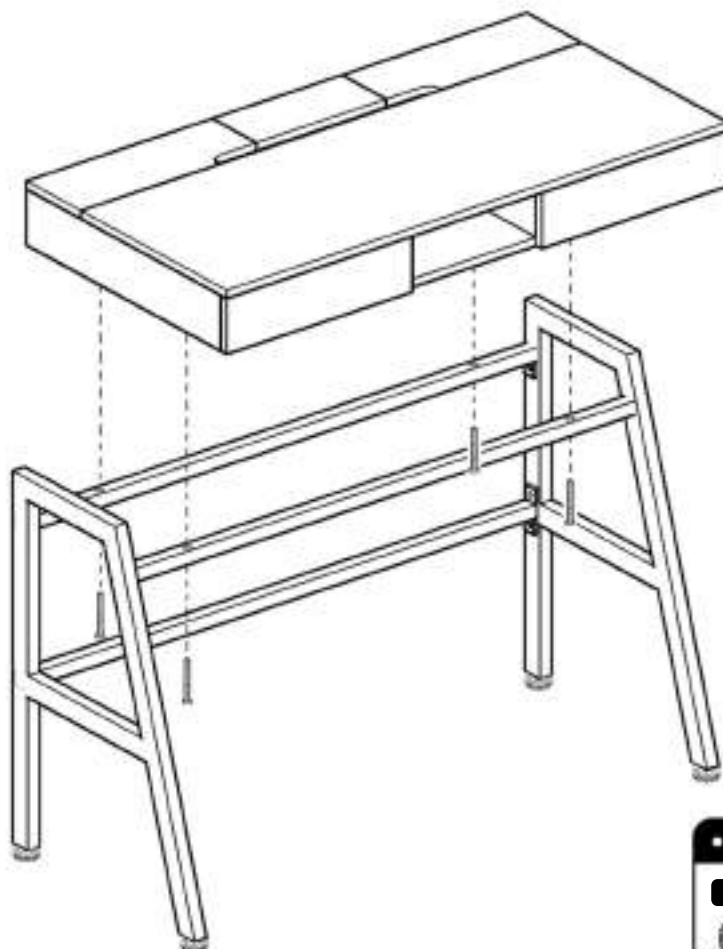

 x 12 

12



• SCREWS

F 6 x 35 MM

 x 4  M4

13



GUDSMITH